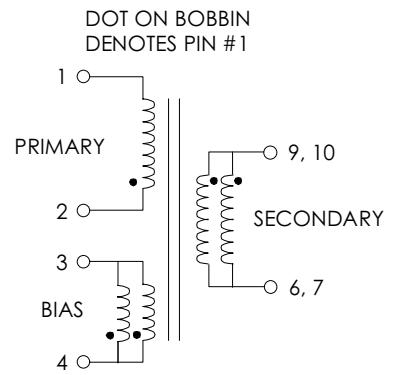

**TABLE 1: ELECTRICAL SPECIFICATIONS AT 25 °C**

SWITCHING TRANSFORMER DESIGNED FOR USE WITH POWER INTEGRATIONS TOP221P (RD7 DEMO BOARD TRANSFORMER TRD1), REFER TO APPLICATION CIRCUIT OF FIGURE 3.

PARAMETER	SPEC LIMITS			UNITS
	MIN.	TYP.	MAX.	
PRIMARY INDUCTANCE (2-1) FREQ. = 100 KHZ @ 0.250Vrms	2.19	2.43	2.67	mHY
TURNRATIO'S: SECONDARY (9-6) : PRIMARY (2-1) BIAS (4-3) : PRIMARY (2-1)	---	1: 19.33 1: 8.29	---	± 4% ± 4%
PRI LEAKAGE IND. (5-10 SHORTED) FREQ. = 100 KHZ @ 0.250Vrms	---	---	70	μHY
HIPOT: PRIMARY TO SECONDARY BIAS TO SECONDARY	3000 3000	---	---	Vrms Vrms
APP CIRCUIT PARAMETERS: (1) DC HOT RAIL VOLTAGE OUTPUT VOLTAGE OUTPUT CURRENT CONTINUOUS OUTPUT CURRENT PEAK LINE REGULATION (90 TO 375Vdc) LOAD REGULATION 10-100% RIPPLE	90 ---	---	375 ---	Vdc Vdc mA mA ±% ±% ±mV

**FIGURE 1: SCHEMATIC DIAGRAM**



**NOTE1:**

- REINFORCED INSULATION SYSTEM, UL1950, IEC950, CSA-950:**  
 A) ALL MATERIALS MEET "UL", "CSA" & "IEC" REQUIREMENTS  
 B) TRIPLE BASIC INSULATED SECONDARY.  
 C) DESIGNED TO MEET ≥6.2mm CREEPAGE REQUIREMENTS.  
 D) VARNISH FINISHED ASSEMBLY.  
 E) UL CLASS (B) 130 INSULATION SYSTEM PM130-R1, PM130-H1, PM130-H1A (UL FILE #E177139) OR ANY UL AUTHORIZED CLASS (B) INSULATION SYSTEM.

(1) REFER TO GENERAL APPLICATION CIRCUIT OF FIGURE 3.

**FIGURE 2: PHYSICAL DIMENSIONS mm (INCHES)**

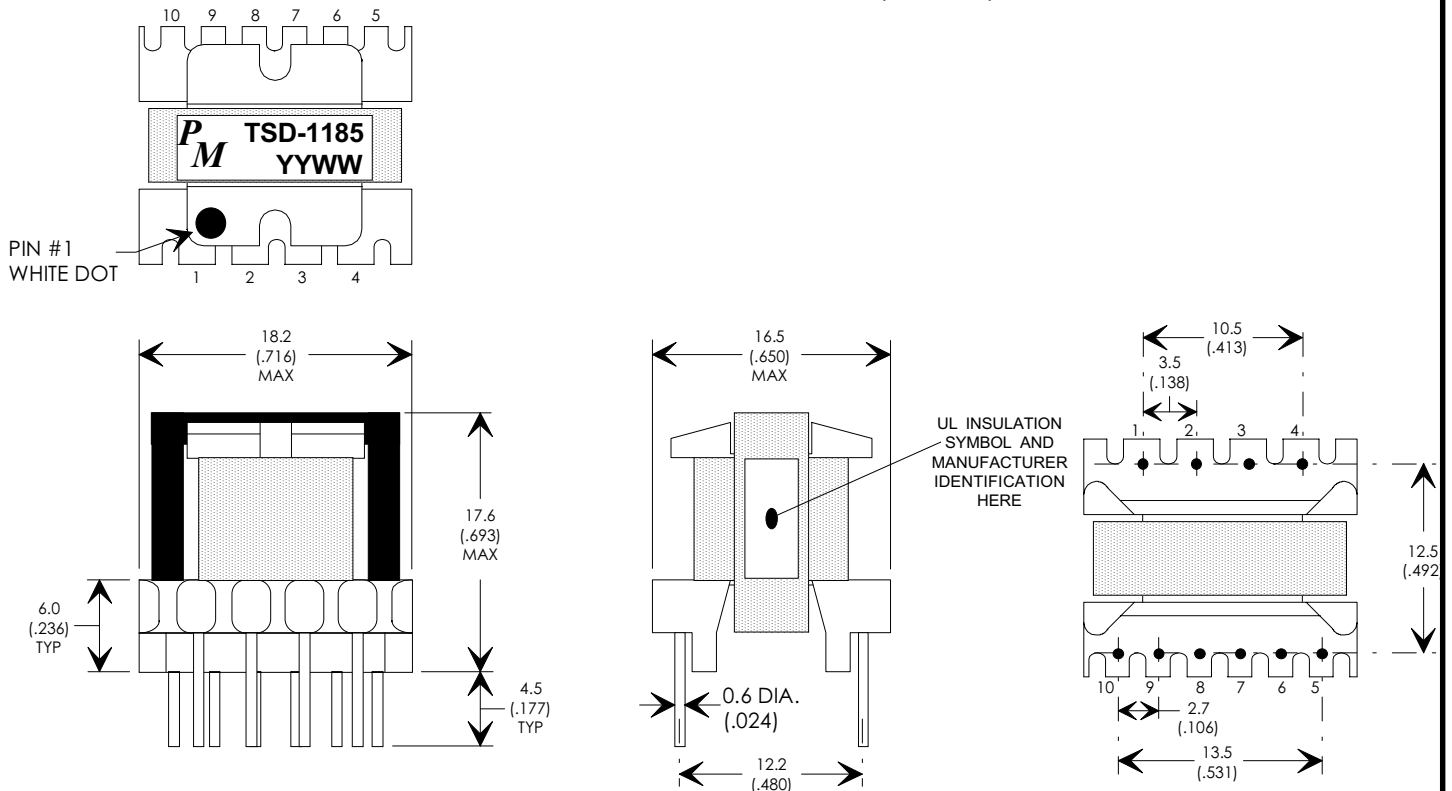

REV.	DESCRIPTION OF CHANGES	BY
04/08/98	ORIGINAL RELEASE	AS
08/24/98	CLARIFY APPLICATION NOTE	PP
01/04/99	CORRECT PRI INDUCTANCE PER CUSTOMER DRAWING	PP
08/13/99	UPDATE TO UL CLASS (B) 130 INSULATION SYSTEM	MD

EE16/EI16, 10-PIN VERTICAL



UNLESS OTHERWISE SPECIFIED DIMENSIONS ARE IN MM  
 DIMENSIONAL TOLERANCES ARE:  
 DECIMALS ANGLES  
 .X ± .25 ±0° 30'  
 .XX ± .15  
 DO NOT SCALE DRAWING

FLYBACK TRANSFORMER CONTROL DRAWING	
PREMIER P/N: TSD-1185	REVISION: 08/13/99
ENGR: AL SANTOS	REF: TOP221P
APPD: TOM O'NEIL	SHEET: 1 OF 6

### APPLICATION NOTES

Premier Magnetics' TSD-1185 Switch Mode Transformer was designed for use with Power Integrations, Inc. PWR-TOP221P three terminal off-line PWM switching regulator in the Flyback Buck-Boost circuit configuration. This conversion topology can provide isolated multiple outputs with efficiencies up to 90%. Premier's TSD-1185 transformer has been optimized to provide maximum power throughput.

The TOPSwitch-II series from Power Integrations, Inc. are self contained 100KHz three terminal voltage controlled PWM switching regulators. This series contains all necessary functions for an off-line switched mode control DC power source. These switching regulators provide a very simple solution to off-line designs. The inductors and transformer used with the TOPXXX are critical to the performance of the circuit. They define the overall efficiency, output power and overall physical size.

Below is a universal input high precision 3.5 watt application circuit utilizing Power Integrations TOP221P switching regulator in the flyback buck-boost configuration. The component values listed are intended for reference purposes only. Please refer to Power Integrations application notes for the RD7 demo board for more information.

**FIGURE 3: TOP221P TYPICAL APPLICATION CIRCUIT**

